



### Introduction

The **AES-Recommendation 2-1984 (r2003)** [01] defines the estimation of linear displacement of a loudspeaker as follows:

*“Voice-coil peak displacement at which the “linearity” of the motor deviates by 10%, X<sub>max</sub>. Linearity may be measured by percent distortion of the input current or by percent deviation of displacement versus input current. Manufacturer shall state method used. The measurement shall be made in free air at f<sub>s</sub>.”*

This definition is not quite clear, and effort has been made by initiative of Wolfgang Klippel to introduce a new standard for definition and measurement of X<sub>max</sub>. This standard is meanwhile available as Draft-Standard **IEC PAS 62458: Sound System Equipment – Electroacoustical transducers – Measurement of large signal parameters**” [02]. The new definition of X<sub>max</sub> is as follows:

*“The voice-coil peak displacement X<sub>max</sub> at which either the total harmonic distortion THD or the nth-order modulation distortion (where n=2 or 3) exceeds 10% in the sound pressure radiated by the driver in free air excited by the linear superposition of a first tone at the resonance frequency f<sub>1</sub>=f<sub>s</sub> and a second tone f<sub>2</sub>=8.5 f<sub>s</sub> with an amplitude ratio of 4:1. The total harmonic distortion assesses the harmonics of f<sub>1</sub> and the modulation distortions are measured by the modulation components f<sub>2</sub> ± (n-1) f<sub>1</sub> according to IEC 60268”.*

### Practical measurement procedure

The Application Note AN4 [03] to the Klippel-Analyzer-System describes a procedure for determining X<sub>MAX</sub>, as defined in IEC PAS 62458. It consists the following steps:

1. Measure the resonance frequency f<sub>s</sub> of the speaker in free air.
2. Operate the test under free-field conditions. Excite the driver with a two tone signal f<sub>1</sub> = f<sub>s</sub> and f<sub>2</sub> = 8.5 f<sub>s</sub> and a amplitude ratio of U<sub>1</sub> = 4\*U<sub>2</sub> and perform a series of measurements with varied amplitudes from U<sub>START</sub> to U<sub>END</sub>.
3. Measure sound pressure in the near field and perform a spectral analysis in order to measure the amplitude of P(f<sub>1</sub>) and P(f<sub>2</sub>), as well as the harmonic components P(k\*f<sub>1</sub>) with k= 2, 3, ... K and of the summed-tone component P(f<sub>2</sub>+(n-1)\*f<sub>1</sub>) and difference-tone components P(f<sub>2</sub>-(n-1)\*f<sub>1</sub>) with n=2, 3 versus amplitude U<sub>1</sub>. Measure the peak-displacement X(f<sub>1</sub>) versus amplitude U<sub>1</sub>.

4. Calculate THD

$$d_1 = \frac{\sqrt{P(2f_1)^2 + P(3f_1)^2 + \dots + P(Kf_1)^2}}{P_1} * 100 \%$$

second order modulation distortion

$$d_2 = \frac{P(f_2 - f_1) + P(f_2 + f_1)}{P(f_2)} * 100 \%$$

third order modulation distortion

$$d_3 = \frac{P(f_2 - 2f_1) + P(f_2 + 2f_1)}{P(f_2)} * 100 \%$$

according to IEC 60628 [04] as a function of U<sub>1</sub>.

5. Search for the minimum value of U<sub>10%</sub> in the range between U<sub>START</sub> and U<sub>END</sub> where either the harmonic distortion d<sub>1</sub> or the second- or third-order modulation distortion d<sub>2</sub> or d<sub>3</sub>, reaches 10%.
6. Determine the peak displacement X<sub>MAX</sub> corresponding to the amplitude U<sub>10%</sub>.

These measurements can also be performed with STEPS ver 1.4 a program of the ARTA-family. Merely the measurement of the membrane displacement differs from the daily measuring routine. In search of an appropriate sensor, the OADM 20I6441/S14F of Baumer [05] was found.



# ARTA - APPLICATION NOTE

## No 7: Estimation of linear Displacement with STEPS

According to specification it has a measuring distance of 50 mm and a measuring range of +/- 20 mm at a resolution of at least 0.02 mm, which should be sufficient in most cases for speaker measurements. A response time of 0.9 ms allows an upper working frequency of about 550 Hz. More detailed information can be found in the abstract of the following specification (figure 1).

general data	
measuring distance $S_d$	30 ... 70 mm
adjustment	Teach-in: button / external
Teach-in range min.	> 2 mm
power on indication	LED green
soiled lens indicator	LED red / LED red blinking
resolution	0,004 ... 0,02 mm
linearity error	$\pm 0,012 \dots \pm 0,06$ mm
light source	pulsed red laser diode
wave length	675 nm
laser class	2
beam type	point
beam diameter	1 ... 0,2 mm
electrical data	
response time / release time	< 0,9 ms
voltage supply range +Vs	12 ... 28 VDC
current consumption max.	120 mA
output circuit	analog
output signal	4 ... 20 mA / 0 ... 10 VDC

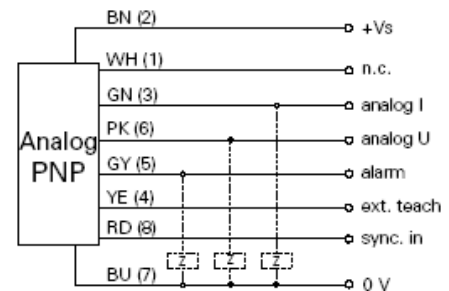
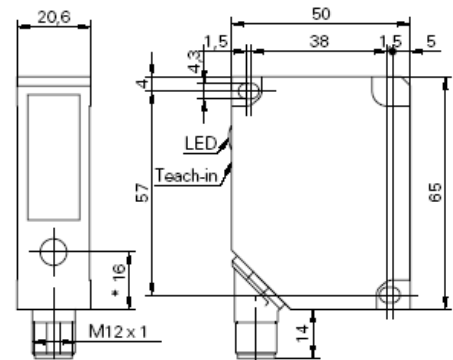

Figure 1. Specification of the Laser Sensor OADM 20I6441/S14F, Baumer [05]

### Setup and basic calibration

The procedure for determining the linear displacement as defined in [02] and [03] with **STEPS 1.4** will be described.

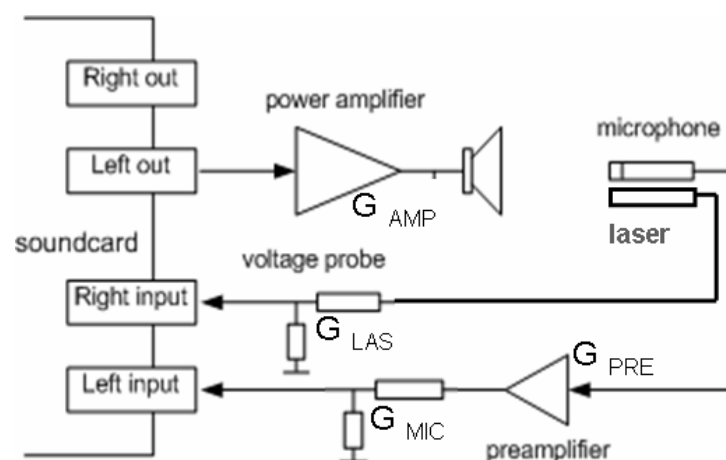

Figure 2. Measurement Setup

Figure 2 shows the measurement setup. The measurement procedure requires two input channels, one for the signal of the microphone and one for the signal of the laser. The output voltages of both sensors



# ARTA - APPLICATION NOTE

## No 7: Estimation of linear Displacement with STEPS

have to be adjusted to the input sensitivity of the soundcard by voltage dividers as shown in figure 2 by  $G_{LAS}$  and  $G_{MIC}$  and figure 3.

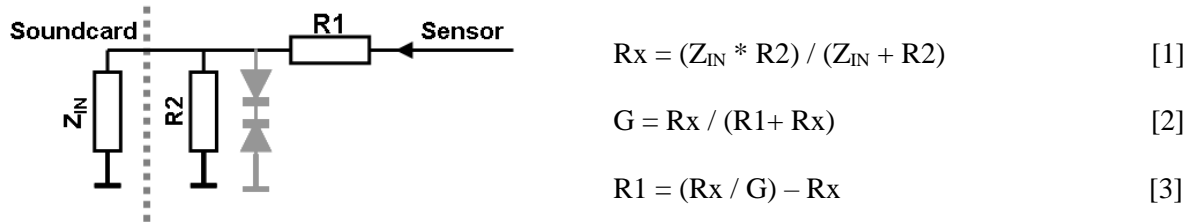
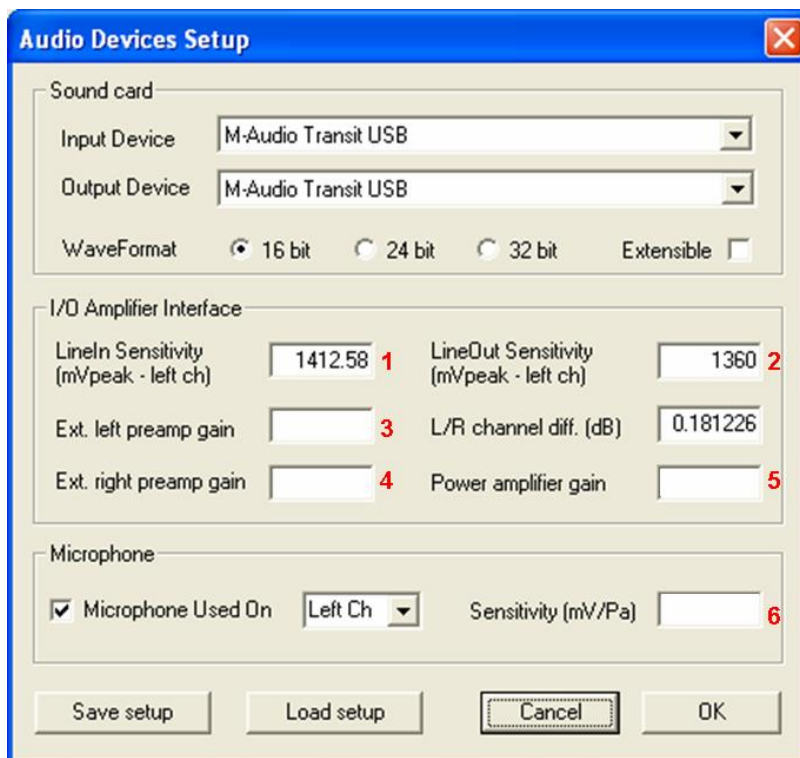

**Figure 3.** Voltage divider for sensors

The laser sensor has a sensitivity of  $10000\text{mV} / 40\text{mm} = 250 \text{ mV/mm}$ . A voltage divider with 12 dB attenuation should work for most sound cards. A second voltage divider has to be dimensioned for the measurement microphone including the microphone preamplifier.

Since both input channels of the sound card are used by the sensors, we are forced to measure in the „Single Channel Mode“. Therefore, for calibrated measurements we need the gain of the power amplifier, additionally.

Figure 4 shows the dialog box „Audio Devices Setup“ of STEPS with all needed calibration data. The calibration is described in the ARTA manual in chapter 1.5 calibration.



- 1 → Basic calibration data of soundcard (Line IN)
- 2 → Basic calibration of soundcard (Line OUT)
- 3 → Attenuation of microphone
- 4 → Attenuation of laser sensor
- 5 → Gain of power amplifier  $G = V_{OUT} / V_{IN}$
- 6 → Sensitivity microphone

**Figure 4.** Audio Devices Setup for calibration of the measuring system



# ARTA - APPLICATION NOTE

## No 7: Estimation of linear Displacement with STEPS

### Preparation and execution of measurement

The loudspeaker has to be fixed vertically in an appropriate jig and the resonance frequency has to be determined with LIMP in stepped sine mode. After that, the microphone and the laser sensor have to be positioned centrally on axis and in front of the membrane (see figure 4).

The positioning of the distance sensor takes place with the help of the laser spot, which should be directed to the middle of the dust cap. The measurement distance should be 50 mm, which equals an output voltage of the laser sensor of exactly 5.0 volt.

The distance of the microphone from the level of the dust cap should add up to about 0.5 of the diameter of the membrane. Please pay attention to the maximum sound pressure of your microphone because we are working in the near field at high pressure levels.



Figure 4: Arrangement of laser and microphone in front of the membrane

Now go to menu “**Record**” and open the option “**Loudspeaker Displacement/Distortion**” and enter measurement **parameters** as mentioned in figure 5.

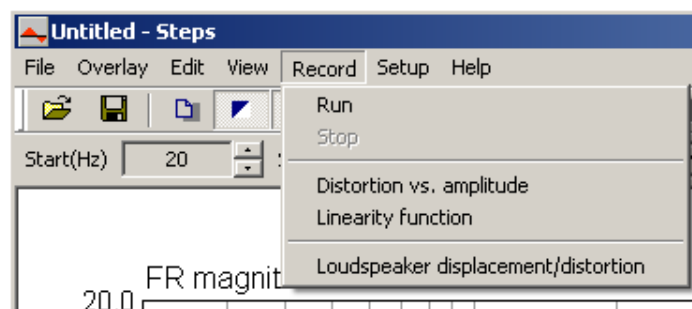



# ARTA - APPLICATION NOTE

## No 7: Estimation of linear Displacement with STEPS

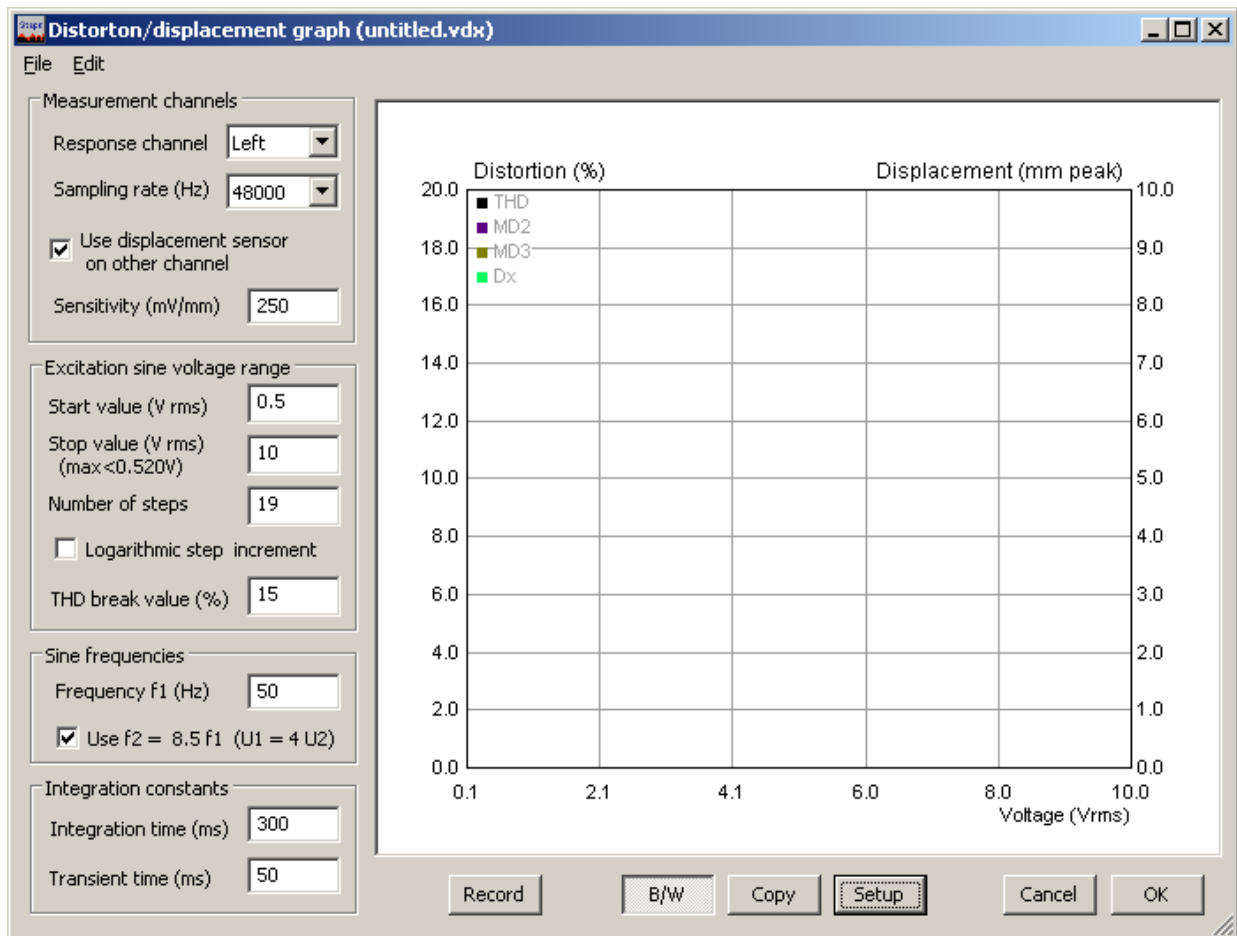

Figure 5. Distortion / Displacement Graph

Figure 5 shows all controls in the “**Distortion/Displacement Graph**” window. They are defined as follows:

### Measurement channels

**Response channel** - define the microphone input channel

**Sampling rate (Hz)** - set the sampling frequency of soundcard

**Use displacement sensor on other channel** - check if displacement sensor is connected to second input channel

**Sensitivity (mV/mm)** - edit sensitivity of displacement sensor

### Excitation sine voltage range

**Start value (V rms)** - edit start value

**Stop value (V rms)** - edit stop value. The maximum value is denoted below this control

**Number of steps** - edit number of measurement steps

**Logarithmic step increment** - switch voltage step to logarithmic increment

**THD break value (%)** - edit distortion limit, after which measurement stops

### Sine frequencies

**Frequency f1 (Hz)** - edit fundamental frequency for harmonic distortions measurement

**Use f2 = 8.5 \* f1 (U1 = 4 \* U2)** – measurement of intermodulation distortions on/off

### Integration constants

**Integration time (ms)** - set rms detector integration time

**Transient time (ms)** - set transient time (time necessary to reach steady state condition)



# ARTA - APPLICATION NOTE

## No 7: Estimation of linear Displacement with STEPS

Before starting the measurement all parameters have to be defined. Most of the parameters in section “**Measurement channels**” are self-explanatory. If a displacement sensor is used the sensitivity has to be put in. In case of the a.m. OADM 20I6441/S14F laser sensor the sensitivity is 250 mV/mm.

Section “**Excitation sine voltage range**” defines the start/stop and break parameters. Please choose these values carefully during your first measurements. In case your basic calibration is not correct there is the danger of overload and damage. Normally the reaching of the “THD break value” or the “Stop value” protects the measurement system and the speaker. To avoid distortion at low excitation levels coming from background noise please start with 0.25 V to 0.50 V. Furthermore choose the number of steps in a way that you will get a readable scale on x axis

$$\text{e.g. } (\text{Stop} - \text{Start}) / \text{Steps} = (10 - 0.5) / 19 = 0.5 \text{ V}$$

In section “**Sine frequencies**” the frequency of excitation has to be defined. As already mentioned this is the resonance frequency of the driver at free air. Please estimate the resonance frequency by using a stepped sine signal of an adequate level. According to IEC PAS 62458 “**Use  $f_2 = 8.5 * f_1$** ” has to be checked.

Start the measurement with “**Record**”. It stops automatically after reaching the maximum defined voltage (Stop Value) or by reaching the given maximum distortion value (THD Break Value). As a result you will get a chart as shown in figure 7.

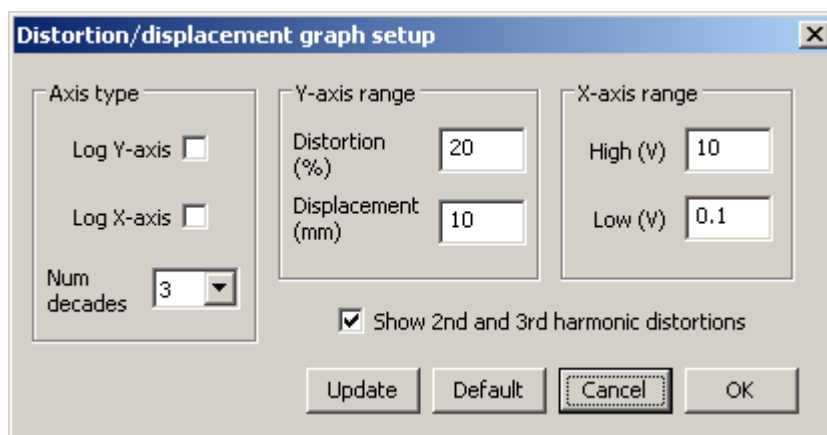

**Figure 6.** Distortion / Displacement Graph Setup

The setup for determining the parameters of the graph is as follows:

#### Axis Type section

**Log Y- axis** - sets logarithmic or linear Y-axis

**Log X- axis** - sets logarithmic or linear X-axis

**Num decades** - sets number of decades in logarithmic Y-axis

#### Y-axis range section

**Distortion (%)** - edits Y-axis range for distortion graph

**Displacement (mm)** - edits box sets Y-axis range for displacement graph

#### X-axis range section

**High (V)** - edits voltage for the graph right margin.

**Low (V)** - edits voltage for the graph left margin.

If check box '**Show 2<sup>nd</sup> and 3<sup>rd</sup> harmonic distortions**' is checked the graph shows additional distortion curves.



# ARTA - APPLICATION NOTE

## No 7: Estimation of linear Displacement with STEPS

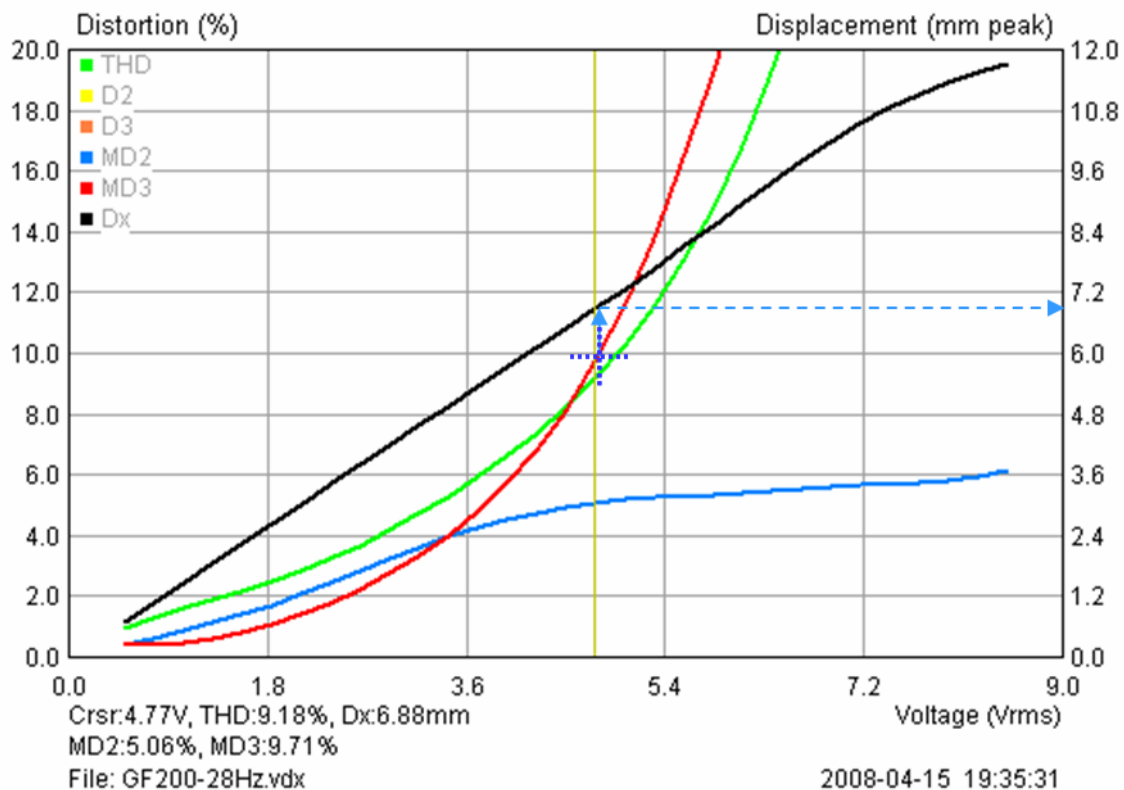

**Figure 7.** Measurement results for a woofer (black = displacement Dx)

Figure 7 shows the result of a combined measurement of displacement / distortion versus voltage. Now we can determine, at which displacement (black line) the speaker produces a distortion of 10 %. It is irrelevant which distortion component reaches the 10 % mark first.

The intersection with the 10 % line (in this case MD3, red line) has to be directed vertically to the displacement line (black) and the new intersection horizontal to displacement axis (see blue arrow). The result of the measurement of the linear displacement may be shown as follows:

Manufacturers Specification	GF 200
Resonance frequency $f_s$	32 Hz
Effective piston area $S_D$	214 cm <sup>2</sup>
Height of pole plate $H$	6 mm
Length of voice coil $L$	20 mm
Mathematical linear displacement $X_{LIN} = L - H$	14 mm
Mathematical displacement volume $V_D = S_D * X_{max}$	299,6 cm <sup>2</sup>
$X_{LIN}$ acc. IEC PAS 62458	
$X_{LIN}$ @ $f_s$ , 10%	14,1 mm
$V_D$ @ $f_s$ , 10%	301,7 cm <sup>2</sup>

Table 1. Specification of displacement data (in mm pp)

As we can see manufacturers data and measured data acc. to IEC PAS 62458 are in good congruity.



# ARTA - APPLICATION NOTE

## No 7: Estimation of linear Displacement with STEPS

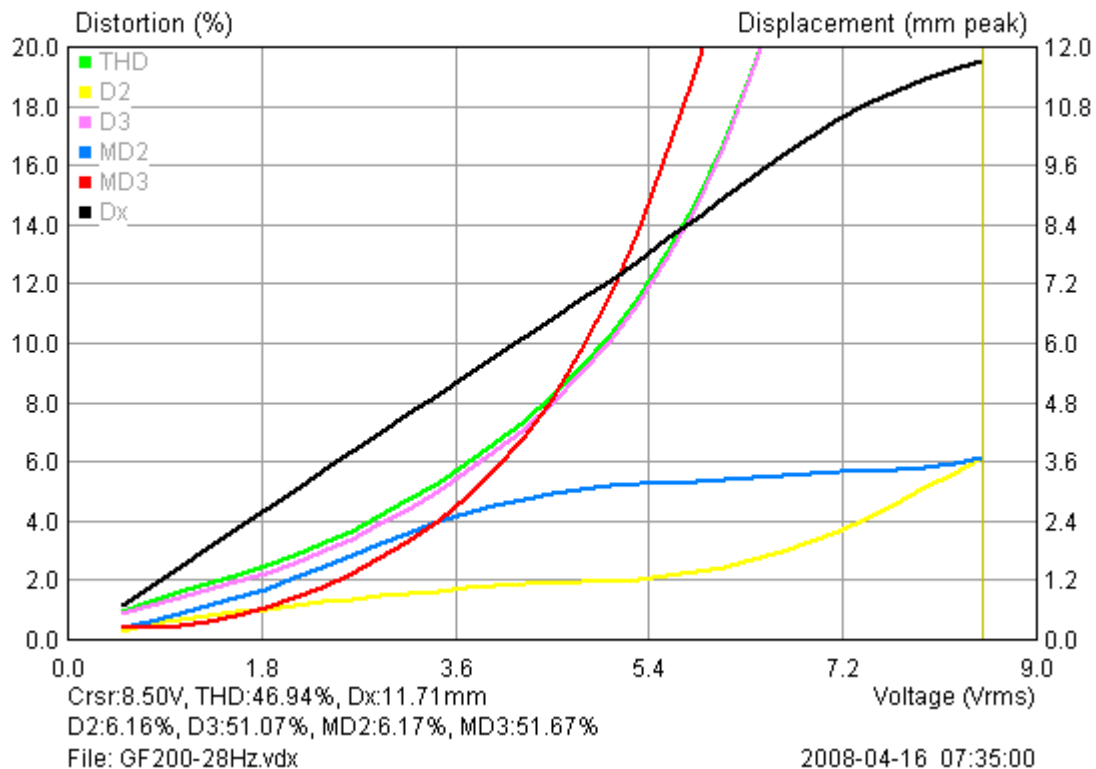

**Figure 8.** Measurement results with all distortions shown

For the interpretation of the results Table 2 might be helpful. In this case you have to check 'Show 2<sup>nd</sup> and 3<sup>rd</sup> harmonic distortions' in the graph setup menu because the harmonic distortions are needed for interpretation. Figure 7 shows an “extended view” of figure 7.

Physical cause	Harmonics		Intermodulation	
	D2	D3	MD2	MD3
Coil offset and asymmetry of BL(x)	X		X	
Coil height		X		X
Asymmetry in suspension	X			
Symmetrical limiting of suspension		X		
Asymmetry in Le(x)			X	
Symmetrical variation in Le(x)				X
Doppler			X	

**Table 2.** Possible physical causes of nonlinearities, after W. Klippel [06]

The order of measured distortions at the voltage of  $X_{LIN}@fs,10\%$  is MD3, D3, MD2, D2. MD3 and D3 indicates the voice coil length as the limiting factor which is in good congruity with the data of Table 1.

Figure 8 shows some other measured samples of different woofers of different manufacturers. Happy interpretations!





# ARTA - APPLICATION NOTE

## No 7: Estimation of linear Displacement with STEPS



Figure 8. Measured results for a collection of different woofers



# ARTA - APPLICATION NOTE

## No 7: Estimation of linear Displacement with STEPS

### Acknowledgement

Our concluding acknowledgement goes to Mr. Jens Jacobi, Baumer GmbH, for providing the laser sensor and to Matthias Leger for taking over most of the measurements.

### Literature

- [01] AES 2-1984 (r2003): AES Recommended Practice, Specification of Loudspeaker Components used in Professional Audio and Sound Reinforcement  
<http://users.skynet.be/william-audio/pdf/aes2-1984-r2003.pdf>
- [02] IEC PAS 62458: Sound System Equipment – Electroacoustical transducers – Measurement of large signal parameters
- [03] AN4 - Measurement of Peak Displacement Xmax - Application Note to the KLIPPEL ANALYZER SYSTEM
- [04] IEC 60268-5: Sound System Equipment – Part 5: Loudspeakers
- [05] Baumer GmbH, Pfingstweide 28, 61169 Friedberg  
Specification OADM20I6441S14F  
<http://www.baumerelectric.com>
- [06] W. Klippel: Assessing Voice Coil Peak Displacement  
<http://www.klippel.de>
- [07] ARTA Kompendium, Revision D 2.1

HWe/IM /04.08